

General Data

Torsion springs, whose ends are rotated in angular deflection, offer resistance to externally applied torque. The wire itself is subjected to bending stresses rather than torsional stresses, as might be expected from the name. Springs of this type are usually close wound, reduce in coil diameter, and increase in body length as they are deflected. The designer must consider the effects of friction and arm deflection on the torque.

Special types of torsion springs include double torsion springs and springs having a space between the coils to minimize friction. Double torsion springs consist of one right-hand and one left-hand coil section connected together, and working in parallel. The sections are designed separately with the total torque exerted being the sum of the two.

Type of Ends

The type of ends on torsion springs should be carefully considered. While there is a good deal of flexibility in specifying special ends and end forming, the cost may be increased and a tool charge incurred. The designer should check nominal free angle

tolerances in Table 2, this section, with respect to application requirements.

Specifications

In addition to supplying the information requested on the torsion spring specification form on page 26, it is important that a drawing be provided detailing the end configurations.

Installation

The type of ends and installation affect spring load and deflection as shown in Figure 1. All torsion springs have three or more points of contact with at least two at the ends and one at the arbor. For clarity, the designer should specify the position of the contact points on the spring and their position relative to one another.

Figure 1.

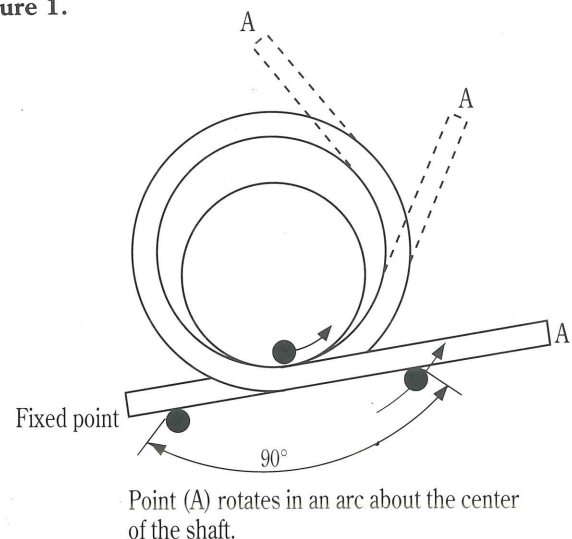

Design Formulas

The basic formulas for torque or moment (M) and bending stress (S) used in designing torsion springs are shown below.

In the formulas the constants 10.8 and 6.6, while not strictly theoretical, give results closer to the actual values obtained.

D = Mean coil diameter, in. (mm)

d = Diameter of round wire, in. (mm)

N_t = Number of coils

E = Modulus of elasticity, psi (MPa)

T = Deflection, number of turns or revolutions of spring

S = Bending stress, psi (MPa)

M = Moment or torque, lb•in. (N•mm)

b = Width, in. (mm)

t = Thickness, in. (mm)

Round Wire

$$(1) M = \frac{Ed^4T}{10.8N_tD}$$

$$(2) S = \frac{32M}{\pi d^3}$$

Rectangular Wire

Wound on Flat

$$(3) M = \frac{Ebt^3T}{6.6N_tD}$$

$$(4) S = \frac{6M}{bt^2}$$

Wound on Edge

$$(3a) M = \frac{Etb^3T}{6.6N_tD}$$

$$(4a) S = \frac{6M}{tb^2}$$

Square Wire

$$(5) M = \frac{Et^4T}{6.6N_tD}$$

$$(6) S = \frac{6M}{t^3}$$

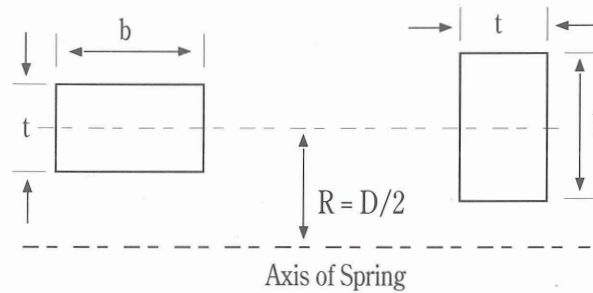

Design Method

The basic design approach is first to calculate the wire diameter (d) in formula 2 using the specified maximum torque (M) and a trial value of maximum design stress (S), which for all materials is assumed to be 75 percent of minimum tensile strength given on pages 44 to 46. If the value of S for the calculated d does not adequately agree with the trial value of S, formula 2 should be used again to calculate an adjusted value of d, this time using the S for the first calculated d rather than the original trial value of S.

When a standard wire diameter just larger than the adjusted value of d is selected, calculate the design stress again in formula 2 for the adjusted value of d and compare it with the maximum allowable design stress. In planning this design, the engineer should carefully consider the pre-loading conditions and the change in spring dimensions with deflection, so that adequate clearance is provided. Springs should be designed to deflect in the direction of winding. This causes the diameter to decrease and length to

increase. The I.D. in the deflected position (I.D._t) can be estimated from

$$I.D._t = I.D. \left(\frac{N_t}{N_t + T} \right)$$

The body length in the deflected position (L_t) is

$$L_t = d (N_t + 1 + T)$$

The longer and more extensively formed the spring arms, the higher the cost for tooling and secondary operations. Therefore, relatively short, straight arms should be specified wherever possible.

Table 1.

TORSION SPRINGS

Coil Diameter Tolerances, ± in. (mm)

Wire Dia., In. (mm)	Spring Index, D/d						
	4	6	8	10	12	14	16
0.015	0.002	0.002	0.002	0.002	0.003	0.003	0.004
(0.38)	(0.05)	(0.05)	(0.05)	(0.05)	(0.08)	(0.08)	(0.10)
0.023	0.002	0.002	0.002	0.003	0.004	0.005	0.006
(0.58)	(0.05)	(0.05)	(0.05)	(0.08)	(0.10)	(0.13)	(0.15)
0.035	0.002	0.002	0.003	0.004	0.006	0.007	0.009
(0.89)	(0.05)	(0.05)	(0.08)	(0.10)	(0.15)	(0.18)	(0.23)
0.051	0.002	0.003	0.005	0.007	0.008	0.010	0.012
(1.30)	(0.05)	(0.08)	(0.13)	(0.18)	(0.20)	(0.25)	(0.30)
0.076	0.003	0.005	0.007	0.009	0.012	0.015	0.018
(1.93)	(0.08)	(0.13)	(0.18)	(0.23)	(0.30)	(0.38)	(0.46)
0.114	0.004	0.007	0.010	0.013	0.018	0.022	0.028
(2.90)	(0.10)	(0.18)	(0.25)	(0.33)	(0.46)	(0.56)	(0.71)
0.172	0.006	0.010	0.013	0.020	0.027	0.034	0.042
(4.37)	(0.15)	(0.25)	(0.33)	(0.51)	(0.69)	(0.86)	(1.07)
0.250	0.008	0.014	0.022	0.030	0.040	0.050	0.060
(6.35)	(0.20)	(0.36)	(0.56)	(0.76)	(1.02)	(1.27)	(1.52)

Table 2.

TORSION SPRINGS

Free Angle Tolerances, ± degrees

Number of Coils N _t	Spring Index, D/d								
	4	6	8	10	12	14	16	18	20
1	2	3	3.5	4	4.5	5	5.5	5.5	6
2	4	5	6	7	8	8.5	9	9.5	10
3	5.5	7	8	9.5	10.5	11	12	13	14
4	7	9	10	12	14	15	16	16.5	17
5	8	10	12	14	16	18	20	20.5	21
6	9.5	12	14.5	16	19	20.5	21	22.5	24
8	12	15	18	20.5	23	25	27	28	29
10	14	19	21	24	27	29	31.5	32.5	34
15	20	25	28	31	34	36	38	40	42
20	25	30	34	37	41	44	47	49	51
25	29	35	40	44	48	52	56	60	63
30	32	38	44	50	55	60	65	68	70
50	45	55	63	70	77	84	90	95	100

Design Example

Design a torsion spring to counterbalance a trap door. The door weighs 20 lb. (9.07 kg) and its width is 18 in. (457.2 mm). The door should remain closed from its own weight, but the spring should hold it open in the upward direction against a stop 110° from the closed position. The material is oil-tempered wire. The spring must work over a 1.10 in. (27.94 mm) diameter shaft.

Wire Diameter

The torque exerted by the door at the closed position is the weight of the door times the distance from the center of gravity to the hinge: 20 lb. × 9 in. = 180 lb. • in. (20,300 N • mm). The spring should be a little weaker so that the door will stay closed, so assume that the spring will carry 90 percent of the weight. Then $M_2 = .90(180) = 162 \text{ lb.} \cdot \text{in.}$ (18,300 N • mm). If a torque of $M_1 = 10 \text{ lb.} \cdot \text{in.}$ (1130 N • mm) is assumed at the open position of the door, the torque should increase 152 lb. • in. (17,200 N • mm) through the 110° deflection.

The first step is to determine the wire diameter which will carry this load. Assuming a minimum tensile strength of 270,000 psi (1862 MPa) in the mid-range for music wire, the trial value of design stress is $S_2 = .75(270,000) = 200,000 \text{ psi}$ (1379 MPa). Transpose stress formula 2 to solve for wire size.

$$d = \sqrt[3]{\frac{32M_2}{\pi S_2}} = \sqrt[3]{\frac{32(162)}{\pi(200,000)}} = 0.202 \text{ in. (5.13 mm)}$$

Seventy-five percent of minimum tensile strength for this wire diameter is $0.75(190,000) = 142,000 \text{ psi}$ (979 MPa). Since this figure is not close enough to 200,000 psi (1379 MPa), wire diameter must be recalculated in formula 2. Therefore, repeat the above calculation with $S = 142,000 \text{ psi}$ (979 MPa).

$$d = \sqrt[3]{\frac{32(162)}{\pi(142,000)}} = 0.226 \text{ in. (5.74 mm)}$$

In this case, proceed using .225 in. (5.72 mm)

The maximum allowable stress for $d = 0.225 \text{ in.}$ (5.72 mm) is $S = 0.75(188,000) = 141,000 \text{ psi}$ (972 MPa). Since the trial stress of 142,000 (979 MPa) is very close to this figure, the design may safely be accepted.

Number of Coils

Transpose the torque formula 1 to solve for number of coils (N_t) using the angular deflection $T = 110^\circ/360^\circ = 0.306$. Choose a diameter which will provide clearance over the 1.10 in. (27.94 mm) shaft. Try a mean diameter of 1.5 in. (38.1 mm) to allow for wire diameter, 10 percent operating clearance, and diameter reduction due to deflection.

$$N_t = \frac{Ed^4T}{10.8DM} = \frac{(30 \times 10^6)(0.225)^4(0.306)}{10.8(1.5)(162 - 10)} = 9.6 \text{ coils}$$

If the design required an exact number of coils such as when the ends must have a particular relationship, formula 1 should be transposed to solve for D using the required number of coils between 9 and 10. The final step is to check the diameter clearance over the shaft and the axial length of the spring with respect to the space available, both in the fully deflected position.

Clearance

The I.D. and body length in the deflected position from free are:

$$I.D._t = I.D. \frac{N_t}{N_t + T} = 1.275 \frac{9.6}{9.6 + 0.326} = 1.233 \text{ in. (31.32 mm)}$$

$$L_t = d(N_t + 1 + T) = .225(9.6 + 1 + 0.306) \\ = 2.458 \text{ in. (62.44 mm)}$$

These compare favorably to the design criteria.

Torsion Springs—Specification Form

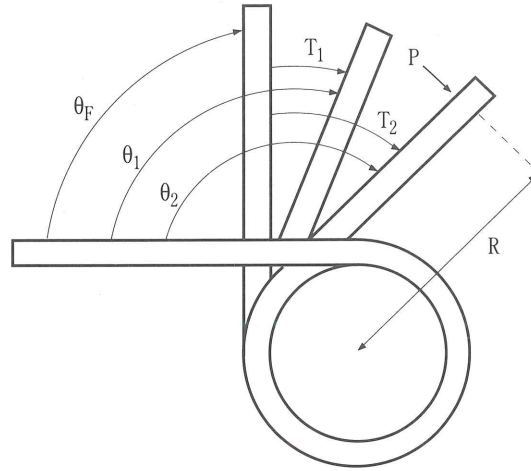
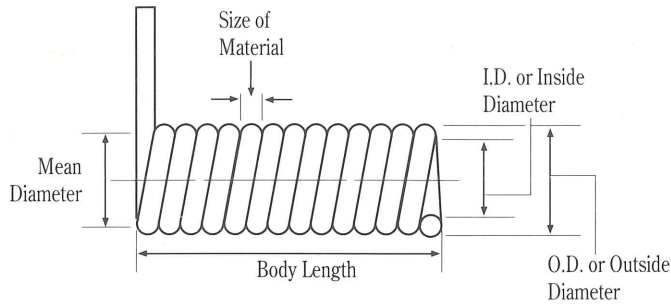

Mandatory Specifications

(fill in only those required)

- To work over _____ in. (mm) dia. shaft.
- OUTSIDE DIAMETER
 - _____ in. (mm) max. or
 - _____ in. (mm) ± _____ in. (mm)
- INSIDE DIAMETER
 - _____ in. (mm) min. or
 - _____ in. (mm) ± _____ in. (mm)
- Torque _____ lb. • in. (N • mm) ± _____ lb. • in. (N • mm) at
 $\theta_1 = \text{_____}^\circ$
 Torque _____ lb. • in. (N • mm) ± _____ lb. • in. (N • mm) at
 $\theta_2 = \text{_____}^\circ$
- Length of space available _____ in. (mm.)
- Maximum wound position _____ turns or _____° from free position.
- Length of moment arm (R) _____ in. (mm)
- Direction of helix (L, R, or optional). _____
- Type of ends _____

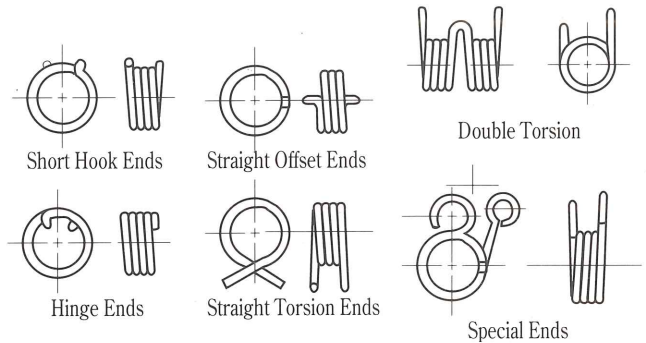

Advisory Data

- Wire diameter _____ in. (mm)
- Mean coil diameter _____ in. (mm)
- No. of coils _____
- Rate _____ lb.-in. (N • mm) per turn (360°).
- $\theta_F = \text{_____}^\circ$ free angle reference

Special Information

- Type of material _____
- Finish _____
- Frequency of rotation, _____ cycles/sec, and working range,
 $\theta = \text{_____}^\circ$ to $\theta = \text{_____}^\circ$ deflection.
- Operating temp. _____ °F (°C)
- End use or application _____
- Other _____